



PRODUCT OPERATING MANUAL

PANBLAST™

PB1000HD BLAST CABINET ASSEMBLY

Manual Number: ZVP-PC-0196-00

SECTION

- 1. GENERAL INFORMATION**
- 2. ASSEMBLY & INSTRUCTIONS**
- 3. OPERATING INSTRUCTIONS**
- 4. MAINTENANCE**
- 5. TROUBLE SHOOTING GUIDE**
- 6. ASSEMBLIES, PARTS LISTING & EXPLODED VIEW**

BLAST CABINET SERIAL NUMBER:

1.0 GENERAL INFORMATION

1.1 Panblast notice to purchasers and users

1.1.1 All products and equipment designed and manufactured by Panblast are intended for use by experienced users of abrasive blasting equipment and its associated operations and abrasive blasting media.

1.1.2 It is the responsibility of the user to:

- Determine if the equipment and abrasive media is suitable for the users' intended use and application.
- Familiarize themselves with any appropriate laws, regulations and safe work practices, which may apply within the users working environment.
- Provide appropriate operator training and a safe working environment including operator protective equipment (PPE) such as, but not limited to, safety footwear, protective eyewear and hearing protection.

1.1.3 Panblast Standard Terms and Conditions of Sale apply. Contact your local Panblast office should you require any further information or assistance.

1.2  **! WARNING! – READ THIS SECTION CAREFULLY BEFORE USING THIS EQUIPMENT/APPARATUS.**

1.2.1 Heavy metal paint, asbestos and other toxic material dusts will cause serious lung disease or death without the use of properly designed and approved air supplied respiratory equipment (SAR) by blast operators and all personnel within the work site area.

1.2.2 The compressor must have adequate output and the plumbing between the compressor and the point of attaching the air supply hose must have sufficient capacity to supply the volume of air at the pressure required.

1.3 Standard safety precautions

1.3.1 Approved safety eyewear, hearing and footwear protection should be worn at all times by the operator(s) and all personnel in the immediate area that may be exposed to any hazards generated by the abrasive blasting process.

1.3.2 Suitably approved respiratory protection should also be worn when handling abrasive media, abrasive refuse dust and when carrying out any service/maintenance work where any dust may be present.

1.3.3 Any work performed on electrical wiring or components must only be carried out by suitably qualified and registered electrical trade's personnel.

1.3.4 Under no circumstances should any safety interlocks/lockouts or features be altered or disabled in any way.

1.3.5 All equipment must be isolated from the compressed air supply and electrical power prior to any service or maintenance work being carried out.

1.3.6 All care must be taken by the operator(s) when lifting or moving equipment or components in order to prevent injury. Blast pots must always

be emptied of abrasive media before any attempt is made to move them

1.3.7 Any modification of the equipment and/or components or use of non-genuine PanBlast™ replacement parts will void warranty.

1.3.8 Always check the Material Safety Data Sheet (MSDS) on the abrasive media being used to ensure that it is free of harmful substances, in particular, free silica, cyanide, arsenic or lead.

1.3.9 Test the surface to be blasted for harmful substances, taking the appropriate measures to ensure the safety of the operator and others.

1.3.10 The operator should carry out a daily inspection of all related components prior to start up of all wearing and safety items to ensure they are in correct operating order. In particular check the blast cabinet safety door interlock system, cabinet lighting, pressure regulator and foot pedal for correct operation. Ensure that all compressed air coupling connections have engaged correctly, the safety locking pins are fitted and in good order. Always install safety whip check cables at every air supply connection. Ensure that the blast nozzle is securely fitted to the suction blast gun assembly and that the suction gun air and abrasive media hoses are securely attached to the suction blast gun.

2.0 ASSEMBLY INSTRUCTIONS

 **! WARNING ! – THE SYSTEM MUST BE IN SHUT DOWN MODE AND THE COMPRESSED AIR DISCONNECTED BEFORE PERFORMING ANY INSTALLATION WORK. FAILURE TO DO SO MAY RESULT IN PREMATURE ACTIVATION OF THE SYSTEM THAT MAY CAUSE SERIOUS INJURY OR DEATH.**

2.1 The PanBlast™ PB1000HD Blast Cabinet is a freestanding unit, which should be installed in a dry area, on a flat and level surface. It is recommended a clear area of 2.4m width x 2.4m depth (9.5m²) be provided around all sides of the cabinet to provide access for operation, loading and servicing.

2.2 The cabinet should only be lifted by the lifting lugs provided using suitable sized lifting equipment in good condition.

2.3 It is recommended that the cabinet be permanently fixed in position with suitably sized fasteners for added stability and safety during use.

2.4 Connect a 1/2" compressed air supply to the inlet of the ball valve on the pressure regulator located on the front of the blast cabinet.

 **! WARNING ! - MINIMUM COMPRESSED AIR SUPPLY VOLUME OF 1.41M³/MIN (50CFM) IS REQUIRED. ALL COMPRESSED AIRLINES, FITTINGS AND CONNECTIONS MUST BE OF THE APPROPRIATE PRESSURE RATING.**

2.5 The compressed air supply must also be clean and dry for the blast cabinet to operate effectively.

2.6 Connect a suitably sized electrical power supply. If the electrical supply is being hard wired into an existing power supply, this must only be

done by a suitably qualified and registered electrical tradesman.

NOTE: THE RECOMMENDED ELECTRICAL SUPPLY IS 415VAC 3 PHASE 10 AMPS.

2.7 Position the cabinet foot pedal at the front of the cabinet in a position, which is comfortable for the operator to use. On some models, the foot pedal may be mounted on a frame attached to the cabinet itself.

2.8 It is recommended that the cabinet foot pedal be fixed in position with suitably sized fasteners for added stability and ease of operation during use.

2.9 The blast cabinet is now ready for operation.

3.0 OPERATING INSTRUCTIONS

3.1 Install the blast cabinet as detailed in Section 2.0 of this manual.

3.2 Remove the abrasive hopper and feed tee assembly from the bottom of the cyclone separator by disengaging the toggle clips located on either side of the hopper assembly.

3.3 Fill the hopper with abrasive media, to a level just below the debris screen located in the top of the abrasive hopper. It is not recommended that the abrasive be filled through the main cabinet door with the hopper fitted, as overfilling may occur.

3.4 Refit the hopper to the cyclone, ensuring that the hopper seal is correctly positioned and seals against the cyclone opening, and that the abrasive pick up hose is inserted into the abrasive feed tee attached to the bottom of the abrasive hopper.

3.5 Turn on the compressed air supply, and slowly open the main ball valve located at the pressure regulator assembly.

3.6 Lift up the pressure regulator control knob to release the lock, and adjust the regulator to the desired blasting pressure. This is done by twisting the adjustment knob clockwise to increase pressure, and twisting counter clockwise to decrease pressure.

3.7 The pressure gauge mounted on the front of the regulator indicates the system air pressure, in both kPa and PSI. Blast pressures of between 275kPa (40psi) to 550 kPa (80psi) are considered normal.

NOTE: AT PRESSURES BELOW APPROXIMATELY 210KPA (30PSI) THE SUCTION GUN MAY NOT OPERATE CORRECTLY.

3.8 Note that it is normal for the system pressure to drop slightly when the blasting action commences. It is best to set the pressure regulator to the desired pressure level while the blasting action is taking place.

3.9 Open the main cabinet door, and load the component to be blasted into the main cabinet area.

3.10 Close the main cabinet door, making sure that the safety door interlock is properly engaged. It is a safety feature that the blasting system will not activate while the cabinet door is open.

3.11 Turn on the main power supply, and switch on the cabinet light at the switch on the front of the cabinet, and start the dust collector fan by depressing the on green button located on the fan starter assembly.

3.12 The system is now ready for blasting operation. Place your hands into the glove openings, and take the blast gun firmly in hand, and depress the foot pedal. The blasting action will now commence.

3.13 The operator should now manipulate the blast gun to move the blasting action over the surface of the component being blasted, until the desired result is achieved. Smooth, continuous strokes over the component surface are normally the most effective, with the nozzle being held approximately 75mm (3") to 125mm (5") from the component surface.

3.14 To stop the blasting action, the operator must remove their foot from the foot pedal.

3.15 Upon completion of blasting, remove the residue of dust from the work piece by using the compressed air blow down gun provided.

3.16 Allow a few moments for the fan and dust collector to clear the airborne dust from the cabinet before opening the cabinet door and removing the work piece/s

3.17 After removing the work piece, close the door, shut off the compressed air supply at the main ball valve.

NOTE: BE SURE TO EMPTY THE MACHINE OF ALL ABRASIVE WHEN SHUTTING DOWN FOR MORE THAN 3-4 HOURS AS THIS WILL REDUCE THE PROBLEMS ASSOCIATED WITH MOISTURE, HUMIDITY, ETC. WHEN STARTING A NEW DAY'S OPERATION.

Blasting adjustments

3.18 As there are many different sizes and types of abrasive blasting media, it is necessary for the system to be adjusted to allow for each abrasive type individual performance characteristics. Most of this adjustment is carried out at the abrasive feed tee assembly, located on the bottom of the abrasive storage hopper.

3.19 The feed tee assembly features an adjustable air bleed valve, which allows air from atmosphere to be drawn into the abrasive pick up hose to mix with the abrasive. Starting with the air bleed valve half open, depress the foot pedal and take note of the abrasive pattern as it exits from the blast nozzle.

3.20 If set correctly, the abrasive should flow smoothly from the blast nozzle, and appear as a fine mist. If there is no abrasive coming from the nozzle, then the air/abrasive mix is too lean, and the air bleed valve needs to be closed further.

3.21 If the abrasive is pulsing or surging from the nozzle, then the air/abrasive mix is too rich,

and the air bleed valve needs to be opened further.

3.22 If the abrasive continues to pulse/surge, even with the air bleed valve fully open, then it is necessary to loosen the two lock nuts, which attach the feed tee to the hopper, and slowly slide the feed tee forward slightly to reduce the orifice opening in the bottom of the abrasive hopper. This adjustment should be carried out in small increments until the abrasive begins to flow smoothly.

3.23 It may be necessary to re-adjust the air bleed valve after the feed tee has been locked back in position, and it is normal for a certain amount of trial and error to be carried out until the correct setting is obtained.

4.0 MAINTENANCE

DAILY SET UP CHECKLIST

⚠ ! WARNING ! - THE COMPRESSED AIR SOURCE MUST BE ISOLATED BEFORE PERFORMING ANY MAINTENANCE WORK. FAILURE TO DO SO MAY CAUSE SERIOUS INJURY OR DEATH.

4.1 On a daily basic

4.1.1 All piping, fittings and hoses must be checked daily for tightness and leakage.

4.1.2 All equipment and components must be thoroughly checked for wear.

4.1.3 All worn or suspect parts must be replaced.

4.1.4 The cabinet viewing window become frosted by the impact from rebounding abrasive; replace the window by unscrewing the four retaining nuts and removing the cabinet widow frame.

⚠ ! WARNING ! - THE CABINET VIEWING WINDOW IS MADE FROM 6MM THICK LAMINATED GLASS. NEVER USE PLAIN PLATE GLASS FOR A CABINET WINDOW, AS SERIOUS INJURY MAY OCCUR.

NOTE: THE SERVICE LIFE OF THE WINDOW WILL BE INCREASED BY ENSURING THAT THE OPERATOR ALWAYS DIRECTS THE BLASTING ACTION AWAY FROM THE WINDOW AS MUCH AS POSSIBLE OR BY USING WINDOW COVER BAC-CA-PB-0392

4.1.5 If moisture separator is fitted, clean filter daily & drain away excess water.

4.1.6 Use abrasive that is properly sized and free of harmful substances such as free silica, cyanide, arsenic or lead. Check for presence of toxic or harmful substances.

4.2 On a weekly basis

4.2.1 On a weekly basis, or when the visibility within the cabinet becomes poor, with the dust collector fan turned off, operate the dust collector pulse system 2-3 times by depressing then releasing the valve lever located on the side of the dust collector behind the main cabinet. Wait a few moments for the dust to settle, then open the drain valve on the bottom of the dust collector and drain the dust into a refuse dustbin. When all the dust has completely

drained out, close the drain valve. Do not over pulse the dust collector cart, as this will cause damage to the filter cartridge media, and this in turn will cause the dust collector to leak dust from the fan outlet.

4.2.2 Open the dust collector inspection door, and visually inspect the filter cartridge for any damage, wear or excessive dust build up. If the filter media is damaged in any way, or there is dust present in the air being discharged from the dust collector, then the filter cartridge should be replaced.

4.2.3 As the abrasive is used, dust and debris may build up in the abrasive mix. This will reduce the performance of the blast gun, increase wear on the gun parts and hoses, and also reduce visibility within the cabinet area. If cabinet visibility does not improve after carrying maintenance as detailed in 4.2.1 and 4.2.3, then it will be necessary to drain all the abrasive from the cabinet, and replace it with new, clean abrasive media.

4.2.4 Visually inspect the cabinet gloves for holes and signs of deterioration. Replace the gloves as necessary.

4.2.5 Inspect the main cabinet door seal around the door opening for wear and damage. Also inspect the abrasive hopper seal and the dust collector inspection door seal for wear and damage. Replace all seals as required.

4.2.6 Inspect the cabinet door safety interlock for condition and operation. The blasting system should not operate with the main cabinet door open. Replace/adjust the door interlock as required.

NOTE: NEVER BYPASS OR DISABLE THE DOOR INTERLOCK AS SERIOUS INJURY MAY OCCUR.

4.3 On a monthly basic

4.3.1 On a monthly basis, remove the blast nozzle from the suction gun, and inspects both the blast nozzle and air tip for wear. If the air tip is worn sufficiently to have either worn through completely, or caused damage to the air tip opening, then the air tip should be replaced.

4.3.2 If the blast nozzle is worn by 1mm (0.040") or more from its original size or of the nozzle insert is grooved or damaged, then the blast nozzle should be replaced.

4.3.3 When re-assembling the Delta style suction gun, the air tip holder must be fully inserted into the gun body until the step/shoulder on the air tip holder is hard up against the rear of the gun body. This will ensure that the air tip is correctly positioned to provide optimum performance.

Abrasives delivery hose

4.3.4 On a monthly basis, inspect the abrasive supply hose along its entire length, by feeling for soft spots, which will indicate areas of wear. If the wear is near the end of the hose, it is permissible to cut off the worn section of hose and re-connect the shortened hose. Otherwise it will be necessary to replace the entire length of hose.

5.0 TROUBLE SHOOTING GUIDE

Item	Problem	Possible Cause	Corrective Actions
1	Blasting system will not operate	No compressed air supply	Check air compressor for operation
		Main ball valve closed	Open ball valve
		Door safety interlock not fully engaged	Check that the main cabinet door is fully closed and the interlock is engaged.
		Door safety interlock faulty	Check/repair/replace door interlock assembly as required
		Air pressure regulator fully turned down or faulty	Check pressure regulator setting
		Faulty foot pedal operation	Check/repair/replace foot pedal assembly as required.
2	Poor visibility in cabinet while blasting	Dirty dust collector bags/cartridge	Operate dust collector shaker/purge system and empty dust collector hopper
		High level of dust in abrasive media	Drain and abrasive from the system and replace with new clean abrasive media
		Dust collector fan damper closed	Adjust fan damper to correct setting
		Blocked/dirty cabinet air inlet filters	Remove, clean and re-fit inlet filters
		Dust collector fan rotation incorrect (3 phase models only)	Have a qualified electrician reverse the direction of fan rotation
		Dust collector fan not operating	Turn dust collector fan on
3	High abrasive media consumption	Abrasive hopper seal leaking or hopper incorrectly fitted	Re-fit hopper and replace seal as required
		Dust collector fan damper open too far	Adjust fan damper to correct setting
		Blast air pressure set too high for abrasive media type	Reduce blasting pressure at pressure regulator
4	Loss of blasting performance	Low abrasive media level	Re-charge system with abrasive media
		Suction gun parts worn, or gun incorrectly adjusted	Dismantle gun assembly and replace parts and adjust as required
		Reduced blasting air pressure	Check pressure regulator and compressed air supply
		Worn blast hose	Check and replace as required
		Incorrect feed tee adjustment	Adjust feed tee to correct setting
5	Dust emission from fan outlet	Damaged or poorly fitted filter bags or cartridges	Check and replace dust bags/cartridges as required, and ensure that fitment is correct
		Dust build up on clean side of dust collector plenum	Clean out dust and check condition and fit of dust bags/cartridges
		Excessive dust build up in refuse dust hopper	Drain dust hopper and clean out as required.
6	Abrasive media surging from blast gun	Incorrect blasting system setting	Refer Section 3.0 for Blasting Adjustment

6.0 ASSEMBLIES, PARTS LISTING AND EXPLODED VIEW

6.1 PanBlast™ PB1000HD Blast Cabinet Assemblies

Stock Code	Description	Weight
BEC-CA-0002-02	PB1000HD Blast Cabinet Assembly	520 kg/(1146 lbs)

6.1.1 PanBlast™ PB1000HD Blast Cabinet Parts Listing

Item	Stock Code	Description	Qty
1	YAC-CA-PB-0101	Window Frame	1
2	BAC-CA-PB-0137	Rectangular Window	1
3	BAC-GL-PB-0003	10" Ø Cabinet Rubber Gloves	1 pr
4	BAC-CA-PB-0157	Cabinet Entry Ring	2
5	BAC-CA-PB-0126	Cabinet Floor Mesh	1
6	BAC-CA-PB-0086	Foot Valve Spring Return	1
7	YAC-CA-PB-0219	Door Interlock Valve	1
8	BAC-CA-PB-0140	Air Entry Filter	2
9	YAC-CA-PB-0145	1/4" Blow Off Gun	2
10	YAC-FN-PB-0041	Toggle Catch	4
11	BAC-DC-PB-0007	Pulse Valve	1
12	BAC-DF-PB-0002	Filter Cartridge - Size 2 (Open/Close)	1
13	YAC-DC-PB-0005	700mm Hanger Rod	1
14	YAC-CA-PB-0146	Handle	4
15	YAC-CA-PB-0205	Handle Tongue	4
16	BAC-PF-PB-0008	38mm (1-1/2") Ball Valve	1
17	BAC-CA-0281-04	Rubber Lined Cyclone	1
18	BAC-CA-PB-0322	Recovery Hose	1
19	BAC-BG-PB-0057	Delta-m Gun GDF 3/16 X 3/8 Assembly	1
20	BAC-RC-PB-0142	Sola5 Inlet Valve Sub Assembly	1
21	BAC-CA-0588-00	Abrasive Hose	1
22	BAC-CA-PB-0220	Feed Tee Assembly	1
23	BAC-AF-PB-0047	13mm (1/2") Filter Regulator With Gauge	1
24	BAC-PF-PB-0001	13mm (1/2") Ball Valve	1
25	BAC-CA-0353-00	Standard Cyclone Screen Seal	1
26	BAC-CA-PB-0178	Cabinet Door Seal	1
27	YAC-CA-PB-0138	Latch	1
28	YAC-CA-PB-0226	Spigot	1
29	BAC-CA-PB-0392	720 X 270 Window Cover - 5pcs	1
30	BAC-CA-PB-0141	Cabinet Window Seal	1
31	BAC-CA-PB-0406	Dust Collector Door Seal	1
32	YAC-CA-PB-0183	Fan Impellor - 360cfm Aluminium	1
33	YAC-CA-PB-0144	1.5kw 415v/50hz Motor	1
34	BAC-CA-PB-0135	Rubber Sealing Grommet	1
35	YAC-CA-PB-0423	16mm Grommet	1
36	YAC-CA-0477-00	Grommet	1
37	BAC-AF-PB-0164	Air Hose 10mm 250psi Impact Blue	2 m
38	BAC-CA-PB-0296	Hinge Assembly	2

6.1.2 PanBlast™ PB1000HD Blast Cabinet Exploded View

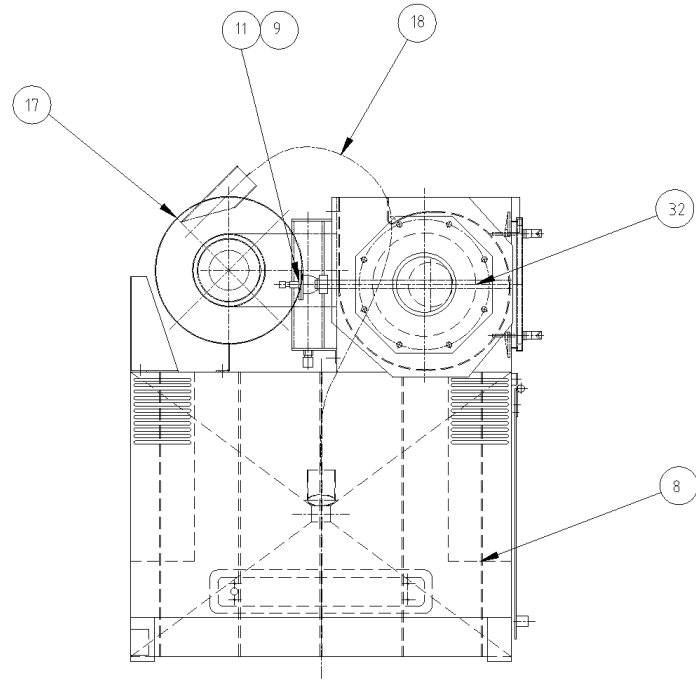

PLAN

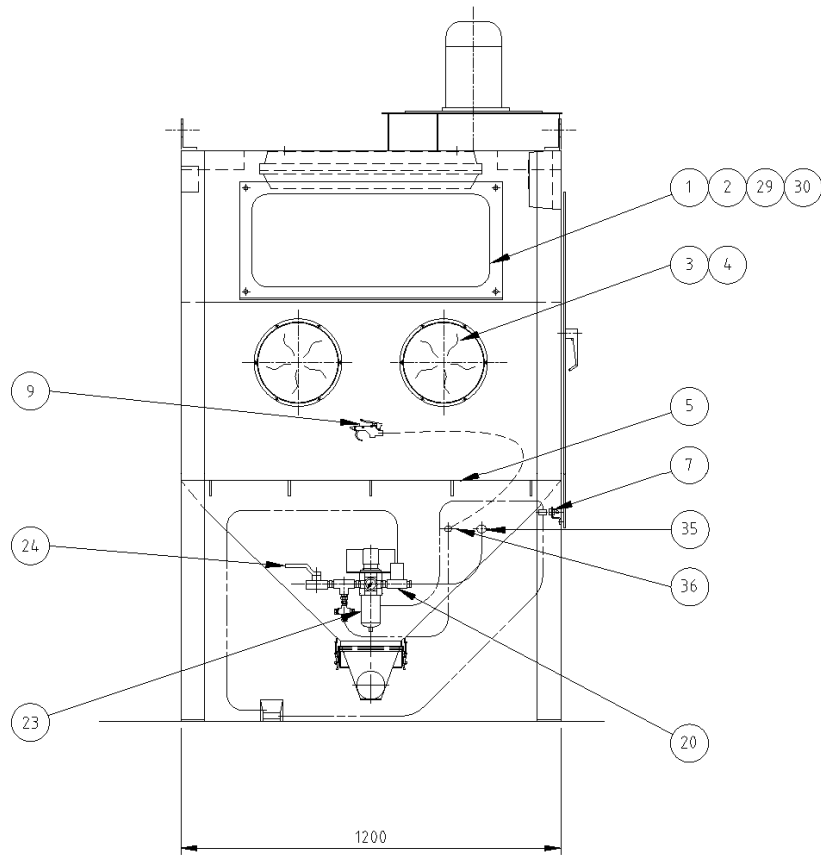

FRONT ELEVATION

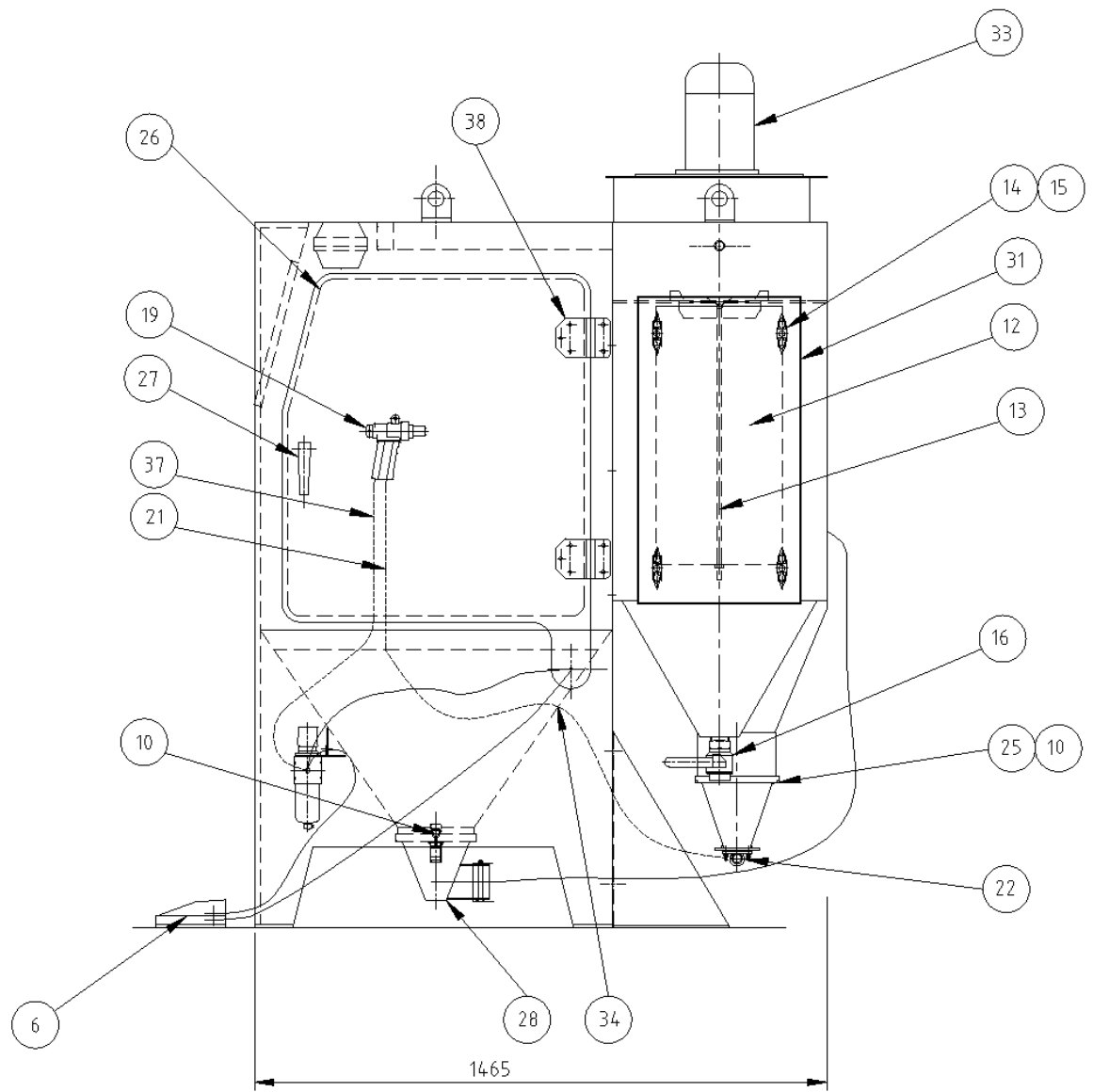

SIDE ELEVATION

6.2 Delta Gun Manual C/W GDF 3/16"X3/8" Parts Listing

Item	Stock Code	Description	Qty
1	YAC-BG-PB-0050	Delta Gun Manual Sub Assy W/O Retainer	1
2	BAC-BG-PB-0013	4.8mm (3/16") Air Jet	1
3	BAC-BG-PB-0028	Delta / gf Nozzle Retainer	1
4	BAC-NZ-PB-0177	Blast Nozzle Godfrey 3/8" Tungsten	1

6.2.1 Delta Gun Manual C/W GDF 3/16"X3/8" Exploded View

