



# PRODUCT OPERATING MANUAL

**PANBLAST™**

***BP110-3 BLAST POT***

***Manual Number: ZVP-PC-0155-00***

**SECTION**

1. GENERAL INFORMATION
2. INITIAL SETUP INSTRUCTIONS
3. OPERATING INSTRUCTIONS
4. MAINTENANCE
5. TROUBLE SHOOTING GUIDE
6. ASSEMBLIES, PARTS LISTING & EXPLODED VIEW
7. COPY OF BLAST POT SHELL CERTIFICATE (IF APPLICABLE)



**BLAST POT SERIAL NUMBER:**

## 1.0 GENERAL INFORMATION

### 1.1 Panblast notice to purchasers and users

1.1.1 All products and equipment designed and manufactured by Panblast are intended for use by experienced users of abrasive blasting equipment and its associated operations and abrasive blasting media.

1.1.2 It is the responsibility of the user to:

- Determine if the equipment and abrasive media is suitable for the users' intended use and application.
- Familiarize themselves with any appropriate laws, regulations and safe work practices, which may apply within the users working environment.
- Provide appropriate operator training and a safe working environment including operator protective equipment (PPE) such as, but not limited to, safety footwear, protective eyewear and hearing protection.

1.1.3 Panblast Standard Terms and Conditions of Sale apply. Contact your local Panblast office should you require any further information or assistance.

### 1.2 ! WARNING! – READ THIS SECTION CAREFULLY BEFORE USING THIS EQUIPMENT/APPARATUS.

1.2.1 Heavy metal paint, asbestos and other toxic material dusts will cause serious lung disease or death without the use of properly designed and approved supplied air respiratory equipment (SAR) by blast operators and all personnel within the work site area.

1.2.2 The compressor must have adequate output and the plumbing between the compressor and the point of attaching the air supply hose must have sufficient capacity to supply the volume of air at the pressure required.

### 1.3 Standard safety precautions

1.3.1 Approved safety eyewear, hearing and footwear protection should be worn at all times by the operator and all personnel in the immediate area that may be exposed to any hazards generated by the abrasive blasting process.

1.3.2 Suitably approved respiratory protection should also be worn when handling abrasive media, abrasive refuse dust and when carrying out any service/maintenance work where any dust may be present.

1.3.3 Any work performed on electrical wiring or components must only be carried out by suitably qualified and registered electrical trades personnel.

1.3.4 Under no circumstances should any safety interlocks/lockouts or features be altered or disabled in any way.

1.3.5 All equipment must be isolated from the compressed air supply and electrical power prior to any service or maintenance work being carried out.

1.3.6 All care must be taken by the operator(s) when lifting or moving equipment or components in order to prevent injury. Blast pots must always

be emptied of abrasive media before any attempt is made to move them.

1.3.7 Any modification of the equipment and/or components or use of non-genuine PanBlast™ replacement parts will void warranty.

1.3.8 Always check the Material Safety Data Sheet (MSDS) on the abrasive media being used to ensure that it is free of harmful substances, in particular, free silica, cyanide, arsenic or lead.

1.3.9 Test the surface to be blasted for harmful substances, taking the appropriate measures to ensure the safety of the operator and others

1.3.10 The operator should carry out a daily inspection of all related components prior to startup of all wearing and safety items to ensure they are in correct operating order. In particular check all hose couplings and nozzle holders, ensuring that all hose couplings are fitted correctly and the safety locking pins are engaged and in good order. Always install safety whip check cables at every hose connection. Ensure that the blast nozzle has been securely screwed into the nozzle holder and the nozzle holder has been secured to the blast hose correctly and all screws are engaged.

**NOTE: UNDER OSHA 1915:34(c)(1)(iv) DEAD MAN CONTROL. A DEADMAN CONTROL DEVICE SHALL BE PROVIDED AT THE NOZZLE END OF THE BLAST HOSE EITHER TO PROVIDE DIRECT CUTOFF OR TO SIGNAL THE POT TENDER BY MEANS OF A VISUAL AND AUDIBLE SIGNAL TO CUT OFF THE FLOW, IN THE EVENT THE BLASTER LOSES CONTROL OF THE HOSE. THE POT TENDER SHALL BE AVAILABLE AT ALL TIMES TO RESPOND IMMEDIATELY TO THE SIGNAL.**

## 2.0 INITIAL SET UP INSTRUCTIONS

### 2.1 Blast pot initial set up

2.1.1 Position the blast pot in the location where it is to be used, preferably on a flat, level surface. Never attempt to move the blast pot when it is full of abrasive media.

2.1.2 Fit the blast hose coupling and nozzle holder to the blast hose, ensuring that the ends of the blast hose are cut square and flat. The blast hose coupling and nozzle holder must be pushed/twisted up onto the blast hose until the end of the blast hose is firmly up against the inside step located inside the blast hose coupling and nozzle holder. Then install the screws supplied with the blast hose coupling and nozzle holder to ensure that they are securely fitted to the blast hose.

** ! WARNING! – NEVER OPERATE/USE A BLAST HOSE WITHOUT THE BLAST HOSE COUPLING AND NOZZLE HOLDER FITTED IN THE CORRECT MANNER.**

2.1.3 Once fitment of the blast hose fittings is completed, connect the blast hose coupling to the abrasive metering valve coupling located on the bottom of the blast pot, making sure that the coupling safety locking pins and safety whip check cables are correctly fitted and form an airtight seal between the two couplings. Then lay the blast hose out flat for its full length.

2.1.4 Securely attach a suitably sized compressed air line to the blast pot main supply ball valve, ensuring that the main supply ball valve is in the closed position. It is preferable for the compressed air line to be at least one size larger than the piping size on the blast pot. Ensure that all coupling safety locking pins and/or locks are correctly fitted to the compressed air connection. Panblast recommends the use of a correctly sized safety whip check cables at all compressed air line connections.

2.1.5 Check that the nozzle holder rubber washer is correctly installed then screw the blast nozzle fully into the nozzle holder, ensuring that it forms a seal against the nozzle holder rubber washer.

2.1.6 The blast pot is now ready for operation.

### 3.0 OPERATING INSTRUCTIONS

#### 3.1 Blasting operating instructions

##### Blast pot operations

**NOTE: CHECK WITH YOUR LOCAL AUTHORITIES TO DETERMINE IF IT IS PERMISSIBLE TO OPERATE A MANUALLY CONTROLLED BLAST POT IN THE LOCAL AREA.**

BP110-3

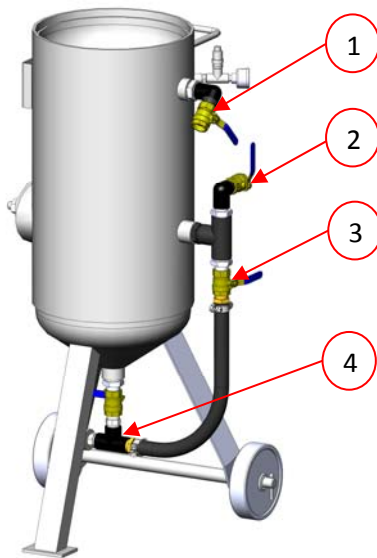

Figure A.

3.1.1 Ensure that the blast pot & air assembly has been set up as detailed in section 2.0 of this manual.

3.1.2 Check that the main supply ball valve (Figure A. no.2) of the blast pot piping is fully closed

3.1.3 Check that the choke line ball valve (Figure A. no. 3) is fully open.

3.1.4 Check that the pot exhaust ball valve (Figure A. no.1) is fully closed.

3.1.5 Fully close the Abrasive ball valve (Figure A. no.4) located on the bottom of the blast pot by turning the control handle to a right angle position.

3.1.6 Load the abrasive media into the blast pot by pouring it in through the pop up valve opening located on top of the blast pot. The blast pot screen (where supplied) should be used to prevent coarse debris and oversize particles from entering the blast pot.

**! WARNING! -DO NOT OVERFILL THE BLAST POT. THE ABRASIVE LEVEL SHOULD REMAIN BELOW THE BOTTOM OF THE POP UP VALVE. TO PREVENT PREMATURE WEAR TO THE EXHAUST BALL VALVE ASSEMBLY.**

3.1.7 Check that all hose connections, fittings, safety locking pins etc. are all secure and in the proper location.

3.1.8 Start the air compressor, and allow the compressor to reach the desired operating pressure. Do not set the blast pressure below 345Kpa (50psi) as the blast pot system may not operate correctly (this is to ensure that the pop up valve will fully close)

**! WARNING! - DO NOT EXCEED THE MAXIMUM OPERATING PRESSURE OF THE BLAST POT AT ANY TIME AS THIS COULD RESULT IN SERIOUS INJURY OR DEATH.**

**NOTE: THE SYSTEM IS NOW READY TO OPERATE AND THE BLAST POT WILL PRESSURIZE IF THE MAIN SUPPLY BALL VALVE IS TURNED ON.**

**THE OPERATOR SHOULD WEAR APPROVED SUPPLIED AIR RESPIRATORY EQUIPMENT (SAR) BEFORE ACTIVATING THE BLASTING MACHINE.**

3.1.9 Pick up the blast hose at the nozzle end, and direct the blast nozzle at the surface/part to be blasted

3.1.10 When appropriate, the blast operator indicates readiness to the pot tender, who then opens the main supply ball valve (Figure A. no.2), and close the exhaust ball valve (Figure A. no.1), which pressurizes the blast pot and lifts the pop up valve. Compressed air will only exit at the blast nozzle.

**! WARNING! - DO NOT OPEN THE MAIN SUPPLY BALL VALVE IF THE BLAST HOSE AND BLAST NOZZLE IS NOT FIRMLY HELD BY THE OPERATOR. AN UNSECURED BLAST HOSE WITH COMPRESSED AIR FLOW WILL WHIP AND MAY CAUSE SERIOUS INJURY OR DEATH.**

**! WARNING! - DO NOT EXCEED THE MAXIMUM OPERATING PRESSURE OF THE BLAST POT.**

3.1.11 Once the blast pot is pressurized check the piping for air leaks. If leaks are found, close the main supply ball valve and open the exhaust ball valve and shut down the compressor before rectifying the air leaks.

3.1.12 If no leaks are found, slowly turn the abrasive ball valve (Figure A. no.4) from the closed 90-degree position until the desired abrasive flow level is achieved. The optimum abrasive flow level will vary depending on actual operating conditions and the desired end result, but as a general rule, the abrasive should appear in the air stream as a fine mist. Once the desired

abrasive flow rate has been achieved, the system is now set for ongoing blasting operations.

**NOTE: FOR FINE ABRASIVE, IT IS NECESSARY TO SLIGHTLY CLOSE THE PUSHER LINE CHOKE BALL VALVE TO INCREASE DIFFERENTIAL PRESSURE TO ASSIST ABRASIVES FLOW THROUGH THE ABRASIVES VALVE.**

**⚠ ! WARNING! - EXCESSIVE THROTTLING OF THE CHOKE VALVE WILL CAUSE HIGH WEAR ON THE ABRASIVES VALVE.**

3.1.13 To stop blasting, the blast operator indicates to the pot tender, who closes the main supply ball valve (Figure A. no.2), and then opens the air exhaust valve (Figure A. no.1), which depressurizes the blast pot and drops the pop up valve.

### 3.2 Shutdown procedure

3.2.1 Close the main supply ball valve located on the blast pot.

3.2.2 Open the air exhaust ball valve (Figure A. no.1), which depressurizes the blast pot to release the pop up valve.



Figure B.

3.2.3 Shut down the air compressor.

3.2.4 Cover the blast machine with the lid (where supplied) and coil up and store the blast hose to prevent accidental damage.

### 4.0 MAINTENANCE

**⚠ ! WARNING! - THE COMPRESSED AIR SOURCE MUST BE ISOLATED BEFORE PERFORMING ANY MAINTENANCE WORK. FAILURE TO DO SO MAY CAUSE SERIOUS INJURY OR DEATH.**

#### 4.1 On a daily basis

4.1.1 If fitted, drain any water/moisture from the moisture separator by opening the drain valve located on the bottom of the water trap bowl. Unscrew the retaining ring and remove the water trap bowl. Check the filter element for blockages and replace as required. Re-fit the bowl and locking ring, and close the bowl drain valve.

**NOTE: IT IS RECOMMENDED THAT THE INCOMING PRESSURIZED AIR BE EQUIPPED WITH A DRYER SYSTEM TO ENSURE THE INLET AIR IS DRY.**

4.1.2 Inspect the blast hose for wear by feeling along its full length for soft spots that indicate wear, and replace the blast hose as necessary.

4.1.3 Check all blast hose couplings are secure and that all safety locking pins are correctly in place.

4.1.4 Remove the safety locking pins and disconnect the couplings by twisting the coupling counter clockwise. Inspect the coupling gaskets for wear and correct seating. Replace the gaskets as required. Reconnect the coupling by engaging the lugs with the blast pot coupling and twisting the hose coupling until fully engaged, and then re-fit the safety locking pins.

#### 4.2 On a weekly basis

4.2.1 Remove the blast nozzle from the nozzle holder by unscrewing the nozzle in a counter-clockwise direction, and inspect it for wear. Replace the nozzle if the internal diameter is worn by 1.5mm (1/16") from its original size, or if the liner is chipped or cracked.

4.2.2 Check the condition of the nozzle washer and replace as required, then re-fit/replace the blast nozzle by screwing it clockwise into the nozzle holder until it is fully sealed against the nozzle washer.

4.2.3 Check the condition of the nozzle holder, and inspect for any cracks or signs of damage. Replace if required as detailed in section 2.1.2.

#### 4.3 On a monthly basis

4.3.1 Inspect the pop up valve located in the top of the blast pot for wear in the form of cracks or grooves (section 6.1.1 item 5). If replacement is required, remove the blast pot shell inspection cover located on the front of the blast pot. Using a suitable pipe wrench, unscrew the vertical pipe section which houses the pop up valve, and remove both the pipe section and pop up valve through the inspection opening. Installation of the new pop up valve is a reversal of the removal procedure and ensures that the pop up valve is positioned directly below the top opening of the blast pot for correct sealing.



Figure C.

4.3.2 Check and inspect the pop up valve seating ring for wear (section 6.1.1 item 4). If replacement is necessary, use a large screwdriver or similar tool to pry the seating ring out of the seat. When re-fitting the seating ring, ensure that it is correctly seated within the seating ring housing.



Figure D.

4.3.3 If fitted, inspect the blast pot exhaust muffler and exhaust line for wear or blockages, replace the worn or blocked muffler and exhaust line as necessary.



5.0 TROUBLE SHOOTING GUIDE

Item	Problem	Possible Cause	Corrective Action
1	Blast pot will not pressurize	No / inadequate compressed air supply	Check that air compressor is operational. Ensure air output and supply hose size is correct.
		Main supply ball valve (Figure A. no.2) is closed	Open ball valve
		Pop up valve / seating ring worn or damaged	Inspect & replace as required
		Exhaust ball valve open.	Close exhaust ball valve.
2	No air and/or abrasive flow from blast nozzle	Blast nozzle blocked	Depressurize system & remove nozzle from it's holder Check & clear any possible blockage. Re-fit nozzle
		Pusher line choke valve fully closed	Open and adjust the choke valve as necessary.
		Abrasive ball valve (Figure A. no. 4) fully closed	Open and adjust abrasive ball valve as required
		Pop up valve or seating ring worn or damaged	Inspect and replace as required
		Insufficient abrasive in blast pot	Refill with abrasive as required
		Excessive dust and fines in abrasive	Drain abrasive from blast pot and refill with clean abrasive
		Damp or wet abrasive in blast pot	Drain abrasive from blast pot and refill with clean abrasive
3	Intermittent abrasive flow	Excessive dust and fines in abrasive	Drain abrasive from blast pot and refill with clean abrasive
		Insufficient abrasive in blast pot	Refill with abrasive as required
		Damp or wet abrasive in blast pot	Drain abrasive from blast pot and refill with clean abrasive
		Excessive abrasive	Check and adjust air pressure as required.
		Compressed air supply pressure too low	
4	Excessive abrasive flow	Abrasive ball valve (Figure A. no.4) fully opened	Adjust abrasive ball valve (Figure A. no. 4) as required
		Pusher line choke valve fully closed	Open & adjust choke valve as required
5	Excessive wear on blast hose	Blast hose kinked or coiled	Keep blast hose as straight as possible without being coiled.
		Blast nozzle excessively worn	Check the internal diameter of blast nozzle and replace if necessary.

## 6.0 ASSEMBLIES, PARTS LISTING & EXPLODED VIEW

### 6.1 PanBlast™ BP110-3 Manual Blast Pot Assembly

Stock Code	Description	Dry Weight	Abrasive Capacity	Piping Size
BEP-PS-PB-0020	BP110-3/AU Manual Ball Valve 150PSI	59kg(130lbs)	31 litres (1.1ft3)	19mm (3/4")
BEP-PS-0066-00	BP110-3/SG Manual Ball Valve			
BEP-PS-0075-00	BP110-3/NZ Manual Ball Valve			

#### 6.1.1 PanBlast™ BP110-3 Manual Blast Pot Parts Listing

Item	Stock Code	Description	Qty
1	BAC-PF-PB-0004	19mm (3/4") Ball Valve	4
2	BAC-PF-PB-0030	6mm (1/4") - 125 PSI Pressure Relief Valve	1
3	BAC-PF-PB-0031	6mm (1/4") Pressure Gauge - Rear Entry	1
4	BAC-BF-PB-0013	Pop Up Valve Seating Ring	1
5	BAC-BF-PB-0012	Pop Up Valve - Stem Type	1
6	BAC-HC-0086-00	STC-1/2 Steel Threaded Pot Coupling	1
7	YAC-PF-PB-0186	KC Nipple	2
8	YAC-FN-PB-0242	Hose Clamp	2
9	YAC-BF-PB-0041	Hose-Air/Water Delivery 19mmIDx29mmOD	0.7 MTR
10	YAC-BF-0231-00	Blast Pot-H/Hole 192x144-Sealing Gasket	1

#### 6.1.2 PanBlast™ BP110-3 Manual Blast Pot Exploded View

