



# PRODUCT OPERATING MANUAL

**PANBLAST™**

***PBF II RESPIRATOR AIRLINE FILTER***

***Manual Number: ZVP-PC-0029-03***

Pressure Equipment Directive 97/23/EC

## **SECTION**

- 1. GENERAL INFORMATION**
- 2. ASSEMBLY INSTRUCTIONS**
- 3. OPERATING INSTRUCTIONS**
- 4. MAINTENANCE**
- 5. TROUBLE SHOOTING GUIDE**
- 6. ASSEMBLIES, PARTS LISTING & EXPLODED VIEW**

## 1.0 GENERAL INFORMATION

### 1.1 Panblast notice to purchasers and users

1.1.1 All products and equipment designed and manufactured by Panblast are intended for use by experienced users of abrasive blasting equipment and its associated operations and abrasive blasting media.

1.1.2 These airline filters are designed to conform to Pressure Equipment Directive 97/23/EC Category I, PS\*DN<3000 for use with compressed breathing air.

Design pressure: 125psi  
Working pressure: 125psi.

1.1.3 It is the responsibility of the user to:

- Determine if the equipment and abrasive media is suitable for the users' intended use and application.
- Familiarize themselves with any appropriate laws, regulations and safe work practices, which may apply within the users working environment.
- Provide appropriate operator training and a safe working environment including operator protective equipment (PPE) such as, but not limited to, safety footwear, protective eyewear and hearing protection.

1.1.4 Panblast Standard Terms and Conditions of Sale apply. Contact your local Panblast office should you require any further information or assistance.

1.2 **⚠ ! WARNING! – READ THIS SECTION CAREFULLY BEFORE USING THIS EQUIPMENT/APPARATUS.**

1.2.1 Heavy metal paint, asbestos and other toxic material dusts will cause serious lung disease or death without the use of properly designed and approved supplied air respiratory equipment (SAR) by blast operators and all personnel within the work site area.

1.2.2 The compressor must have adequate output and the plumbing between the compressor and the point of attaching the air supply hose must have sufficient capacity to supply the volume of air at the pressure required.

### 1.3 Standard safety precautions

1.3.1 Approved safety eyewear, hearing and footwear protection should be worn at all times by the operator and anyone else in the immediate area that may be exposed to any hazards generated by the abrasive blasting process.

1.3.2 Suitably approved respiratory protection should also be worn when handling abrasive media, abrasive refuse dust and when carrying out any service/maintenance work where any dust may be present.

1.3.3 Any work performed on electrical wiring or components must only be carried out by suitably qualified and registered electrical trades personnel.

1.3.4 Under no circumstances should any safety interlocks/lockouts or features be altered or disabled in any way.

1.3.5 All equipment must be isolated from the compressed air supply and electrical power prior to any service or maintenance work being carried out.

1.3.6 All care must be taken by the operator(s) when lifting or moving equipment or components in order to prevent injury. Blast pots must always be emptied of abrasive media before any attempt is made to move them.

1.3.7 Any modification of the equipment or and/or components use of non-genuine PanBlast™ replacement parts will void warranty.

1.3.8 Always check the Material Safety Data Sheet (MSDS) on the abrasive media being used to ensure that it is free of harmful substances, in particular, free silica, cyanide, arsenic or lead.

1.3.9 Test the surface to be blasted for harmful substances, taking the appropriate measures to ensure the safety of the operator and others.

1.3.10 The operator should carry out a daily inspection of all related components prior to start up of all wearing and safety items to ensure they are in correct operating order.

In particular check all hose couplings and nozzle holders, ensuring that all hose couplings are fitted correctly and the safety locking pins are engaged and in good order. Always install safety whip check cables at every hose connection. Ensure that the blast nozzle has been securely screwed into the nozzle holder and the nozzle holder has been secured to the blast hose correctly and all screws are engaged.

## 2.0 ASSEMBLY INSTRUCTIONS

2.1 These instructions cover the operation and maintenance of the PanBlast™ PBF II Respirator Airline Filters.

2.2 The PanBlast™ PBF II-1, PBF II-3 and PBF II-4 Respirator Airline Filters are industrial grade breathing air filters, designed to remove water, odor and taste from the incoming respirator compressed air supply.

**NOTE: THE PBF RESPIRATOR AIRLINE FILTER WILL NOT REMOVE CARBON MONOXIDE, CARBON DIOXIDE AND ANY OTHER TOXIC OR HAZARDOUS GAS.**

2.3 As the quality of air from different compressors varies, the Respirator Airline Filter may need additional purification filtration devices for removal of oil mist, carbon monoxide, carbon dioxide and toxic gases to produce air that meet the overall air quality requirements of the applicable local statutory authority regulations of the country where the product is being used, examples of which are as follows:

CE: EN 12021  
OSHA Grade D Breathing Air

2.4 Never connect a respirator airline to an air source that has not been tested for gas or particulate contamination. The presence of unacceptable levels of carbon monoxide (CO) in

the breathing air will cause death to the operator.

- 2.5 It is not recommended to use piston type or oil bath compressors for breathing air. Use of these types of compressors poses an extreme danger of producing unacceptable levels of carbon monoxide in breathing air which could cause death to the operator.
- 2.6 Do not use any caustic chemicals or solvents that may be irritating or harmful to the user, or which change the properties of the materials used in any part of the PBF II Respirator Airline Filter assembly.
- 2.7 The design Approvals and Standards applicable to the PBF II unit applies only when used as a complete system as supplied, without any modification, deletion or substitution.
- 2.8 The quality of air supplied to the supplied air respirator is critical to the safety and comfort of the operator. Special care must also be taken to avoid accidental connection to any other gas lines; such as oxygen, acetylene or nitrogen etc. Air used to supply the supplied air respirator must be filtered quality breathing air. Relevant regulatory standards for breathing air supply include (but not limited to): AS/NZS 1715 (Australia/New Zealand), EN12021 (CE) and Grade D (NIOSH).
- 2.9 Air supplied by oil lubricated air compressors must be equipped with a high temperature alarm or a carbon monoxide (CO) alarm, or both. If only a high temperature alarm is used, the air from the compressor must be tested frequently for the presence of carbon monoxide (CO). It is the operator's responsibility to check the air supply. This includes the compressor, carbon monoxide alarms, air filters and shut down devices. An overheated compressor or one that is in poor mechanical condition may produce carbon monoxide (CO) and objectionable odors. A carbon monoxide (CO) removal system may also be used to ensure breathing air quality.
- 2.10 When breathing air is supplied by oil lubricated and oil less air compressors, certain precautions must be taken. The compressor inlet must be located away from all sources of toxic contaminants including carbon monoxide which is found in the engine exhaust and in any combustion of oil products. No vehicles should be allowed near the compressor intake. Other contaminants that may be harmful to the operator can enter the respiratory equipment through the compressor air inlet. This inlet must not be located in proximity to any exhaust system outlet, ventilation flue or source of fumes or particles of any kind.
- 2.11 The precautions described above also apply to portable compressors. In addition, in the case of engine driven compressors, precautions must be taken to prevent engine exhaust gases from entering the air intake of the compressor. Compressor engine exhaust should be piped to a location safely downwind from the compressor air intake. Compressors vary in design and operation; therefore it is important that users carefully read the manufacturers' operation and maintenance instructions.
- 2.12 The PanBlast™ PBF II Respirator Airline Filters are available in three (3) different configurations.

The PBF II-1 unit is designed for single operator use, the PBF II-3 is designed for up to three (3) operators, while the PBF II-4 is designed for up to four (4) operators.

### 3.0 OPERATION INSTRUCTION

- 3.1 Remove the PBF assembly from the packaging and install the three legs and regulator kit.
- 3.2 Place it on a flat, level surface and check the lid retaining bolts are all securely tightened.
- 3.3 Check that the compressed air regulator and pressure relief valve are securely fitted to the PBF lid assembly.
- 3.4 Ensure that the mini ball valve located on the bottom of the PBF filter housing is in the closed position.
- 3.5 Screw a suitable size and type of compressed air fitting (by purchaser) to suit your compressed air supply hose. For PBF-1 a minimum hose size of 13mm (1/2") is recommended, while for the PBF-3 and PBF-4 a minimum hose size of 19mm (3/4") is recommended.
- 3.6 Now connect your breathing airline hoses to the breathing air quick disconnect fitting(s) located on the PBF pressure regulator outlet/manifold.
- 3.7 Slowly open the compressed air supply to the PBF unit and check the system for any compressed air leaks.
- 3.8 Adjust the PBF pressure regulator to the specified pressure required for the blasting helmet and breathing airline hose length utilized.
- 3.9 The PBF system is now ready for operation.

### 4.0 MAINTENANCE

- 4.1 Using the mini ball valve located on the bottom of the PBF housing, drain any moisture/water from the PBF after every four (4) hours of operation.
- 4.2 The PBF filter cartridge should be replaced after every three (3) months, based on forty (40) hours of operation per week.
- 4.3 The filter cartridge should be replaced whenever:
  - 4.3.1 The user(s) detect any objectionable odors.
  - 4.3.2 The filter begins to pass any water through to the outlets.
  - 4.3.3 The outlet pressure nears the lowest pressure recommended for the blast helmet being used.

**⚠ ! WARNING! - BEFORE REPLACING THE FILTER CARTRIDGE ENSURE THAT THE COMPRESSED AIR SUPPLY IS SHUT OFF; ALLOW THE COMPRESSED AIR TO COMPLETELY BLEED OUT VIA THE DRAIN VALVE AND THE PRESSURE GAUGE MUST READ ZERO**

- 4.4 To replace the PBF filter cartridge, remove the eight (8) lid retaining bolts and lift the lid from the PBF assembly.

- 4.5 Carefully lift the PBF Flanged Filter Cartridge out of the housing.
- 4.6 Clean and dry the internal area of the PBF housing and remove any foreign objects/debris.
- 4.7 Carefully insert the new filter cartridge (BAC-AF-PB-0055) into the housing.
- 4.8 Position the lid onto the housing while aligning the bolt holes, taking care not to damage or pinch the lid seal.
- 4.9 Re-fit the lid retaining bolts and tighten the bolts to a torque setting of 60Nm.
- 4.10 Re-connect the compressed air supply and check the PBF unit for leaks.

5.0 TROUBLE SHOOTING GUIDE

Item	Problem	Possible Cause	Corrective Action
1	Air leakage	Loose fittings	Tighten the fitting with PTFE sealing tape if necessary
		Gasket worn or damaged	Inspect & replace as required
2	No/low air flow	No / inadequate compressed air supply	Check and ensure air compressor is operational.
		Inlet pressure set too low	Adjust pressure regulator to increase pressure.
		Mini ball valve opened	Shut off the mini ball valve
		Choked cartridge	Replace cartridge
		Defective regulator	Replace regulator

**6.0 ASSEMBLIES, PARTS LISTING & EXPLODED VIEW****6.1 PanBlast™ PBF II-1 Respirator Airline Filter Assembly**

Stock Code	Description	Weight
BAC-AF-0001-10	PBF II-1 Respirator Airline Filter	12 Kg (26.46lbs)

**6.1.1 PanBlast™ PBF II-1 Respirator Airline Filter Parts Listing**

Item	Stock Code	Description	Qty
1	YAC-AF-0012-05	PBF Body	1
2	BAC-AF-0013-07	PBF Filter Lid	1
3	BAC-PF-PB-0030	6mm (1/4") BSP - 125 PSI Pressure Relief Valve	1
4	YAC-FN-PB-0031	Hex Head Bolt	8
5	YAC-FN-PB-0030	M10 Nut	8
6	YAC-FN-PB-0017	Flat Washer	16
7	YAC-FN-PB-0016	Spring Washer	8
8	YAC-PF-PB-0167	Mini Ball Valve	1
9	YAC-AF-0265-01	Support Leg	3
10	YAC-FN-PB-0111	Hex Head Bolt	3
11	YAC-FN-PB-0006	M6 Nut	3
12	YAC-FN-PB-0007	Flat Washer	6
13	YAC-FN-PB-0008	Spring Washer	3
14	BAC-AF-PB-0055	PBF Flanged Filter Cartridge	1
15	YAC-PF-PB-0100	Elbow	1
16	YAC-PF-PB-0099	Nipple	1
17	YAC-AF-PB-0018	3/8" Regulator	1
18	YAC-PF-PB-0092	Quick Disconnect Fitting Male	1
19	BAC-PF-PB-0213	3mm (1/8") Pressure Gauge - Rear Entry	1
20	YAC-NP-0130-00	P.E.D. 97/23/EC CE Label	1
21	YAC-FN-PB-0054	Pop Rivet	4

**6.1.2 PanBlast™ PBF II-1 Respirator Airline Filter Service Kit**

Stock Code	Description
BAC-AF-PB-0007	PBF-1 Regulator Kit - Includes Items 15, 16, 17, 18, 19

6.1.3 PanBlast™ PBF II-1 Respirator Airline Filter Exploded View

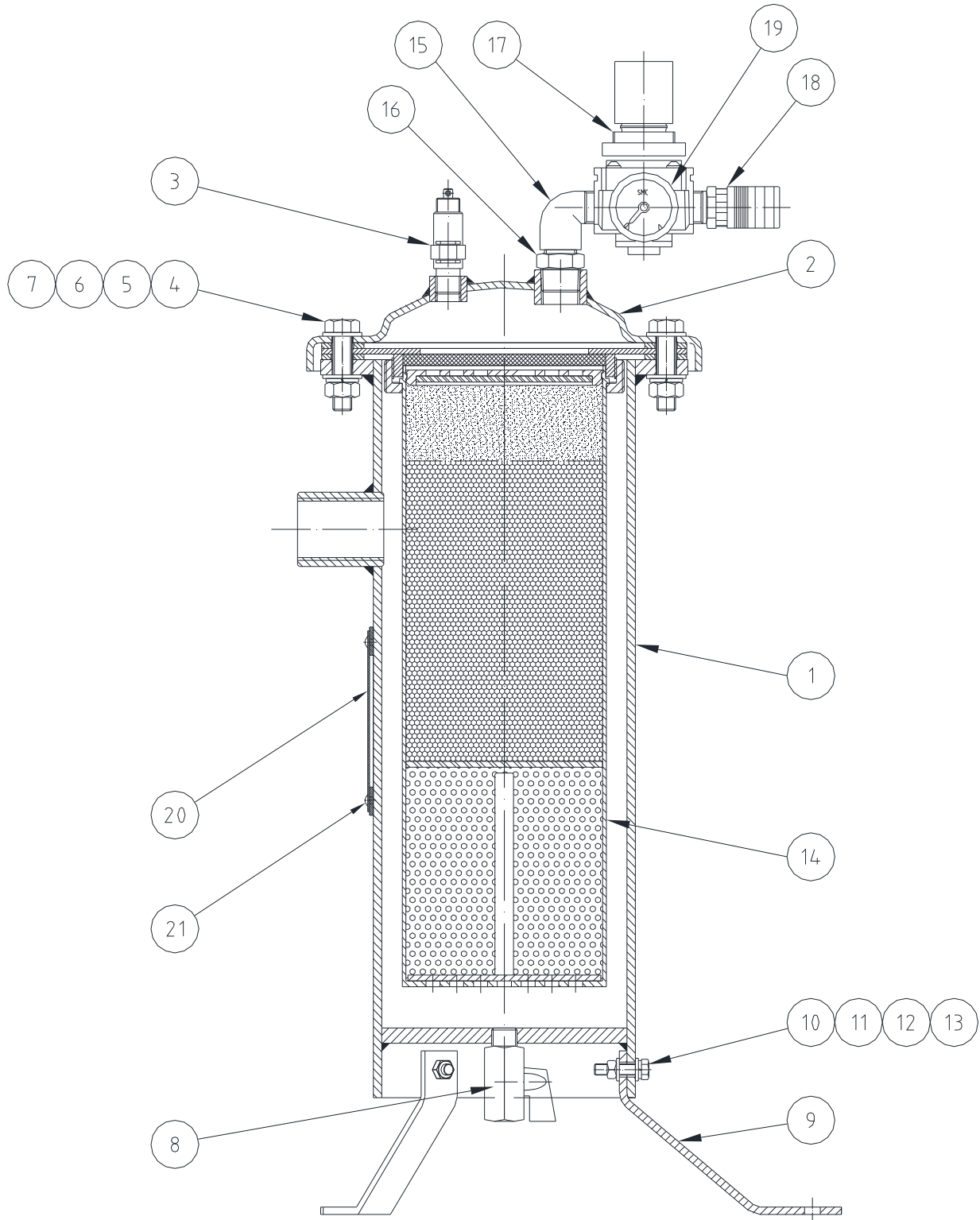



**6.2 PanBlast™ PBF II-3 Respirator Airline Filter Assembly**

Stock Code	Description	Weight
BAC-AF-0003-11	PBF II-3 Respirator Airline Filter	13.5 Kg (29.76lbs)

**6.2.1 PanBlast™ PBF II-3 Respirator Airline Filter Parts Listing**

Item	Stock Code	Description	Qty
1	YAC-AF-0012-05	PBF Body	1
2	BAC-AF-0013-07	PBF Filter Lid	1
3	BAC-PF-PB-0030	6mm (1/4") BSP - 125 PSI Pressure Relief Valve	1
4	YAC-FN-PB-0031	Hex Head Bolt	8
5	YAC-FN-PB-0030	M10 Nut	8
6	YAC-FN-PB-0017	Flat Washer	16
7	YAC-FN-PB-0016	Spring Washer	8
8	YAC-PF-PB-0167	Mini Ball Valve	1
9	YAC-AF-0265-01	Support Leg	3
10	YAC-FN-PB-0111	Hex Head Bolt	3
11	YAC-FN-PB-0006	M6 Nut	3
12	YAC-FN-PB-0007	Flat Washer	6
13	YAC-FN-PB-0008	Spring Washer	3
14	BAC-AF-PB-0055	PBF Flanged Filter Cartridge	1
15	YAC-PF-PB-0099	Nipple	2
16	YAC-AF-PB-0019	1/2" Regulator	1
17	BAC-PF-PB-0031	6mm (1/4") Pressure Gauge - Rear Entry	1
18	YAC-PF-PB-0092	Quick Disconnect Fitting Male	3
19	YAC-AF-0020-02	Air Manifold - 1/2" X 4 Outlet 3/8"	1
20	YAC-PF-PB-0116	Plug	1
21	YAC-NP-0130-00	P.E.D. 97/23/EC CE Label	1
22	YAC-FN-PB-0054	Pop Rivet	4

**6.2.2 PanBlast™ PBF II-3 Respirator Airline Filter Service Kit**

Stock Code	Description
BAC-AF-PB-0008	PBF-3 Regulator Kit - Includes Items 15(2 Off), 16, 17, 18(3 Off), 19, 20

6.2.3 PanBlast™ PBF II-3 Respirator Airline Filter Exploded View

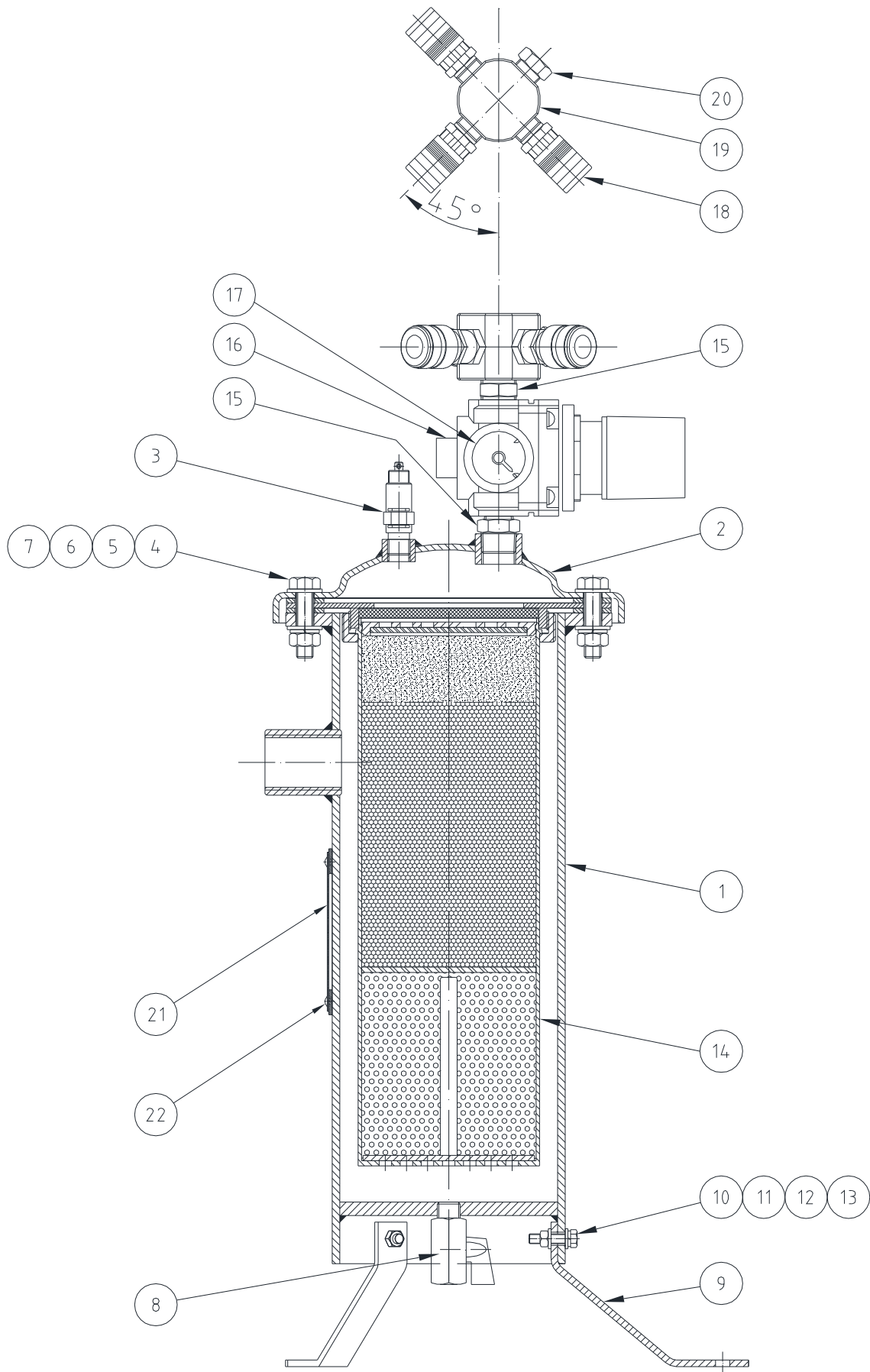

**6.3 PanBlast™ PBF II-4 Respirator Airline Filter Assembly**

Stock Code	Description	Weight
BAC-AF-0004-10	PBF II-4 Respirator Airline Filter	14.3 Kg (31.46lbs)

**6.3.1 PanBlast™ PBF II-4 Respirator Airline Filter Parts Listing**

Item	Stock Code	Description	Qty
1	YAC-AF-0012-05	PBF Body	1
2	BAC-AF-0013-07	PBF Filter Lid	1
3	BAC-PF-PB-0030	6mm (1/4") BSP - 125 PSI Pressure Relief Valve	1
4	YAC-FN-PB-0031	Hex Head Bolt	8
5	YAC-FN-PB-0030	M10 Nut	8
6	YAC-FN-PB-0017	Flat Washer	16
7	YAC-FN-PB-0016	Spring Washer	8
8	YAC-PF-PB-0167	Mini Ball Valve	1
9	YAC-AF-0265-01	Support Leg	3
10	YAC-FN-PB-0111	Hex Head Bolt	3
11	YAC-FN-PB-0006	M6 Nut	3
12	YAC-FN-PB-0007	Flat Washer	6
13	YAC-FN-PB-0008	Spring Washer	3
14	BAC-AF-PB-0055	PBF Flanged Filter Cartridge	1
15	YAC-PF-PB-0099	Nipple	2
16	YAC-AF-PB-0019	1/2" Regulator	1
17	BAC-PF-PB-0031	6mm (1/4") Pressure Gauge - Rear Entry	1
18	YAC-PF-PB-0092	Quick Disconnect Fitting Male	4
19	YAC-AF-0020-02	Air Manifold - 1/2" X 4 Outlet 3/8"	1
20	YAC-NP-0130-00	P.E.D. 97/23/EC CE Label	1
21	YAC-FN-PB-0054	Pop Rivet	4

**6.3.2 PanBlast™ PBF II-4 Respirator Airline Filter Service Kit**

Stock Code	Description
BAC-AF-PB-0009	PBF-4 Regulator Kit - Includes Items 15(2 Off), 16, 17, 18(4 Off), 19

6.3.3 PanBlast™ PBF II-4 Respirator Airline Filter Exploded View

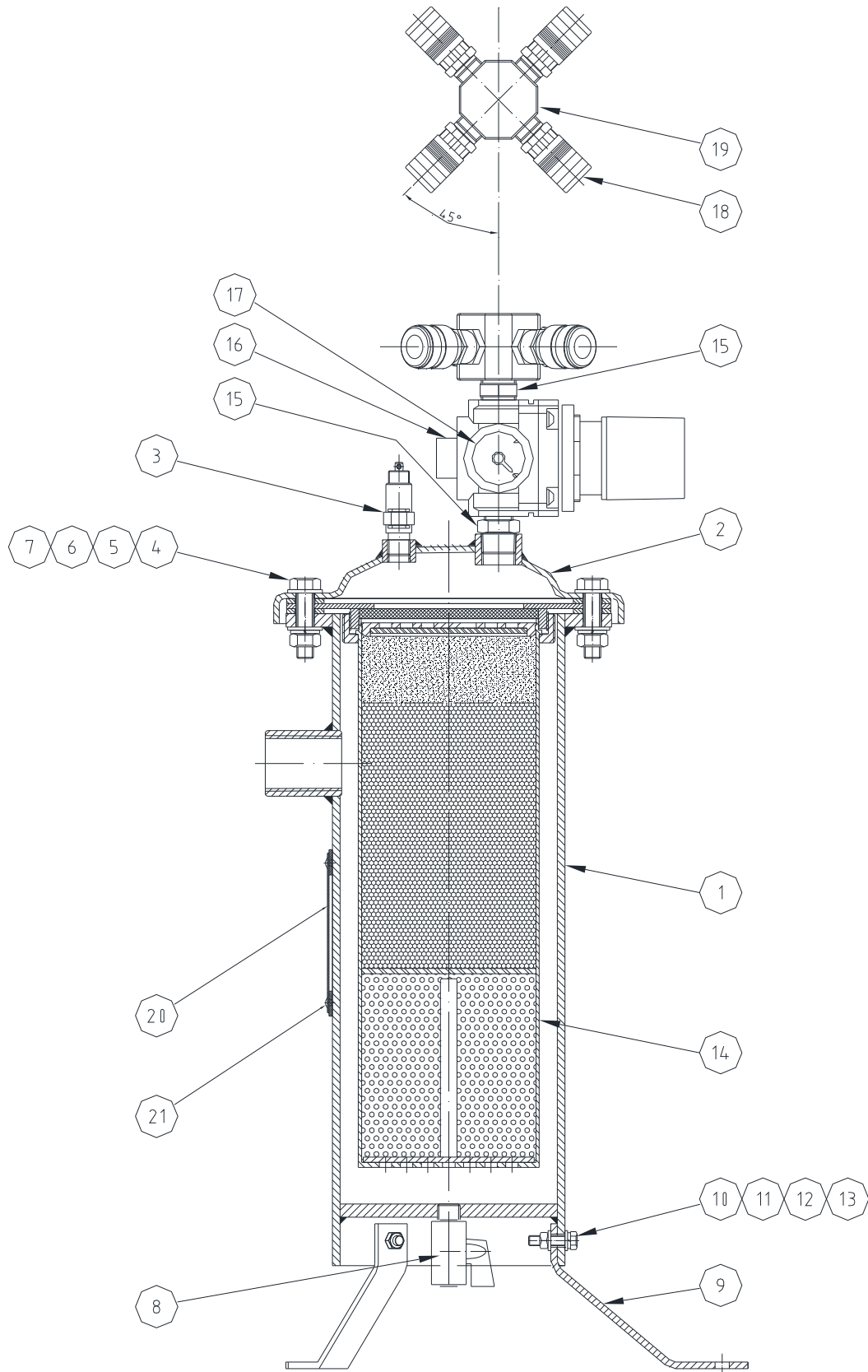

**6.4 PanBlast™ PBF Flanged Filter Assembly**

Stock Code	Description	Weight
BAC-AF-PB-0055	PBF Flanged Filter Conversion Kit	1.60 Kg (3.53lbs)

**6.4.1 PanBlast™ PBF Flanged Filter Parts Listing**

Item	Stock Code	Description	Qty
1	BAC-AF-PB-0002	PBF Filter Cartridge	1
2	YAC-AF-PB-0054	Cradle Flange-Flg Filter Cartridge Kit	1
3	YAC-AF-PB-0053	Gasket	2
4	YAC-AF-PB-0056	Rubber Seal	1
5	YAC-AF-PB-0068	Cradle Nut	1

**6.4.2 PanBlast™ PBF Flanged Filter Service Kit**

Stock Code	Description
YAC-AF-PB-0097	Flanged Adaptor Parts Kit - Includes Items 2, 3(2 Off), 4, 5

**6.4.3 PanBlast™ PBF Flanged Filter Exploded View**

